



Technical Data
Caractéristiques techniques

LTM 1090/2

Mobile Crane
Grue automotrice

Telescopic boom

Flèche télescopique

171 ft

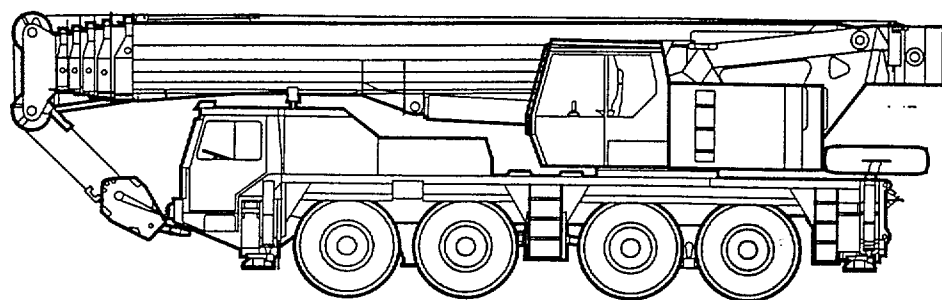

LIEBHERR



Lifting capacities at telescopic boom. Forces de levage à la flèche télescopique.

LTM 1090/2



38 ft - 171 ft

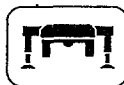

0° / 360°



44 100 lbs

85%

ft	38 ft		51 ft	63 ft	75 ft	87 ft	99 ft	111 ft	124 ft	136 ft	148 ft	160 ft	171 ft	ft
	1)													
10	216	179												10
11	204	179												11
12	191	175	165	143										12
13	178	167	160	137										13
14	167	160	156	132	114									14
15	156	152	151	127	110	98.5								15
16	146	145	144	123	107	95.5								16
17	138	138	138	118	103	92.5	80.5	69.5						17
18	131	131	130	115	99.5	89.5	78	68						18
20	117	117	116	107	93	84	74	65.5	56.5					20
22	106	106	105	98	87.5	78.5	70.5	62.5	54.5					22
24	96	95.5	94.5	88.5	81	74	67	59.4	52.4	45.5				24
26	87.5	85	84	79	73.5	69.5	63.5	56.7	50.2	44.1				26
28			76	71.5	66.5	63.5	60	54.2	48	42.5	36.3			28
30			69	64.5	60	57.9	56.6	51.8	45.9	40.9	35.4	28.9		30
32			63	58.9	55	53	51.9	49.6	44	39.4	34.5	28.2		32
34			58.1	54.3	50.6	48.9	48	47	42.2	38	33.6	27.6	23.4	34
36			53.8	50.4	46.8	45.3	44.6	44.1	40.5	36.6	32.6	26.9	22.8	36
38			49.5	46.4	43.1	41.7	41.2	41.1	38.8	35.2	31.6	26.2	22.2	38
40				42.8	39.7	38.5	38.1	38.4	36.9	33.9	30.6	25.6	21.7	40
45				36.2	33.2	32.3	32.1	32.6	31.5	30.9	28.1	24.1	20.4	45
50				32.6	28.2	27.4	27.4	29.2	27.1	27.6	25.8	22.8	19.2	50
55					23.9	24.8	23.4	26.6	23.9	24.3	23.5	21.5	18.1	55
60						22.9	20.1	24	22	21.2	21.2	20.3	17.1	60
65							21.2	18.1	21.3	20.3	18.7	19	18.8	65
70							19.7	16.8	18.7	18.4	17.2	17.6	17.1	70
75								15.6	16.5	16.4	16.2	16	15.3	75
80								14.6	14.6	14.5	15.1	14.2	13.6	80
85								13.8	12.9	13.3	13.5	12.6	11.9	85
90									11.5	12.5	12.1	11.2	10.4	90
95									10.9	11.6	10.8	10	9.2	95
100										10.6	9.7	8.9	8.2	100
105										9.6	8.8	8	7.3	105
110										8.9	8	7.3	6.5	110
115											7.4	6.6	5.8	115
120											6.8	6	5.2	120
125												5.4	4.6	125
130												4.9	4.1	130
135												4.6	3.6	135
140													3.2	140
145														145
150														150
I	0	0/0	46/0	92/0	92/0	92/0	92/0/0	92/0/0	92/0	92/46	92	100	I	
II	0	46/0	46/0	46/0	92/0	92/0	92/92/0	92/92/46	92/92	92/92	92	100	II	
III	0	0/0	0/0	0/0	0/92	46/92	46/92/92	92/92/92	92/92	92/92	92	100	III	
IV	0	0/0	0/46	0/46	0/46	0/92	46/46/92	46/92/92	46/92	92/92	92	100	IV	
V	0	0/46	0/46	0/92	0/46	0/46	0/46/92	0/46/92	46/92	46/92	92	100	V	

1) over rear / en arrière.

TAB 107033 / 107035

Remarks referring to load charts.

- The tabulated lifting capacities do not exceed 85 % of the tipping load.
- The crane's structural steelwork is in accordance with DIN 15018, part 3. Design and construction of the crane comply with DIN 15018, part 2, and with F. E. M. regulations.
- The 85 % overturning limit values take into account wind force 5 = wind speed 20 mph.
- Lifting capacities are given in kips.
- The weight of the hook blocks and hooks must be deducted from the lifting capacities.
- Working radii are measured from the slewing centreline.
- The lifting capacities given for the telescopic boom only apply if the folding jib is taken off.
- Lifting capacities are subject to modifications.
- Lifting capacities above 179 kips only with additional pulley block / special equipment.

Remarques relatives aux tableaux des charges.

- Les forces de levage indiquées ne dépassent pas 85 % de la charge de basculement.
- La norme DIN 15018, 3ème partie est appliquée pour les charpentes. La construction de la grue est réalisée conformément à la norme DIN 15018, 2ème partie, et aux règles de la F. E. M.
- A 85 % de la charge de basculement, il a été tenu compte d'un vent de force 5 = vitesse de vent 20 mph.
- Les forces de levage sont données en kips.
- Le poids des moufles et crochets doit être soustrait des charges indiquées.
- Les portées sont calculées à partir de l'axe de rotation.
- Les forces indiquées pour la flèche télescopique s'entendent fléchette dépliée déposée.
- Les forces de levage sont modifiables sans préavis.
- Forces de levage plus de 179 kips seulement avec équipement supplémentaire.

Lifting capacities are given



38 ft - 171 ft



0° / 360°



31 800 lbs

85%

ft	38 ft		51 ft	63 ft	75 ft	87 ft	99 ft	111 ft	124 ft	136 ft	148 ft	160 ft	171 ft	ft
	1)	2)												
10	216	179												10
11	201	179												11
12	187	174	165	143										12
13	173	166	160	137										13
14	162	158	156	132	114									14
15	151	150	150	127	110	98.5								15
16	142	142	141	123	107	95.5								16
17	134	134	133	118	103	92.5	80.5	69.5						17
18	126	126	126	113	99.5	89.5	78	68						18
20	113	112	111	102	92.5	83.5	74	65.5	56.5					20
22	102	100	97.5	89.5	82	76.5	70.5	62.5	54.5					22
24	92	89	86	78.5	73	69.5	65.5	59.4	52.4	45.5				24
26	83.5	79	76	69.5	64.5	62	60	56.7	50.2	44.1				26
28			68.5	63	58.4	56.1	54.7	53.2	48	42.5	36.3			28
30			62	56.8	52.7	50.8	49.7	49.4	45.8	40.9	35.4	28.9		30
32			56.6	51.7	48	46.3	45.5	45.4	43.2	39.4	34.5	28.2		32
34			52	47.6	44.1	42.6	41.9	42	40.4	37.8	33.6	27.6	23.4	34
36			47.8	44	40.7	39.4	38.9	39	37.6	36.2	32.6	26.9	22.8	36
38			45.5	40.4	37.3	36.2	35.8	36.8	34.8	34.6	31.6	26.2	22.2	38
40				37.8	34.2	33.2	33	35.2	32.2	32.8	30.6	25.6	21.7	40
45				34.9	28.4	29.7	27.5	31.2	28.4	27.9	27.4	24.1	20.4	45
50				30.9	24.5	27.1	23.3	27.2	25.9	24	23.9	22.8	19.2	50
55					22.7	24.7	21.4	23.6	23.1	21.1	21.6	20.9	18.1	55
60						22.3	19.6	20.6	20.3	19.6	19.8	18.5	17.1	60
65						19.5	18.1	18	17.9	18.4	17.5	16.3	15.9	65
70						17.2	16.8	15.7	16.3	16.2	15.3	14.5	14.2	70
75							15.3	14.1	14.9	14.3	13.3	12.7	12.4	75
80							13.6	13.1	13.3	12.6	11.6	10.9	10.7	80
85							12.7	12.2	11.9	11.1	10.1	9.4	9.2	85
90								11.3	10.6	9.8	9	8.3	8.1	90
95								10.3	9.5	8.8	8	7.3	7.1	95
100									8.6	7.9	7.1	6.4	6.3	100
105										7.9	7.1	6.3	5.6	105
110										7.3	6.4	5.6	4.9	110
115											5.8	5	4.3	115
120											5.3	4.5	3.7	120
125												4	3.2	125
130												3.6	2.7	130
135												3.2		135
I	0	0/0	46/0	92/0	92/0	92/0	92/0/0	92/0/0	92/0	92/46	92	100	I	
II	0	46/0	46/0	46/0	92/0	92/0	92/92/0	92/92/46	92/92	92/92	92	100	II	
III	0	0/0	0/0	0/0	0/92	46/92	46/92/92	92/92/92	92/92	92/92	92	100	III	
IV	0	0/0	0/46	0/46	0/46	0/92	46/46/92	46/92/92	46/92	92/92	92	100	IV	
V	0	0/46	0/46	0/92	0/46	0/46	0/46/92	0/46/92	46/92	46/92	92	100	V	

1) over rear / en arrière.

TAB 107034 / 107036

Les forces de levage sont données



Lifting heights. Hauteurs de levage.

LTM 1090/2

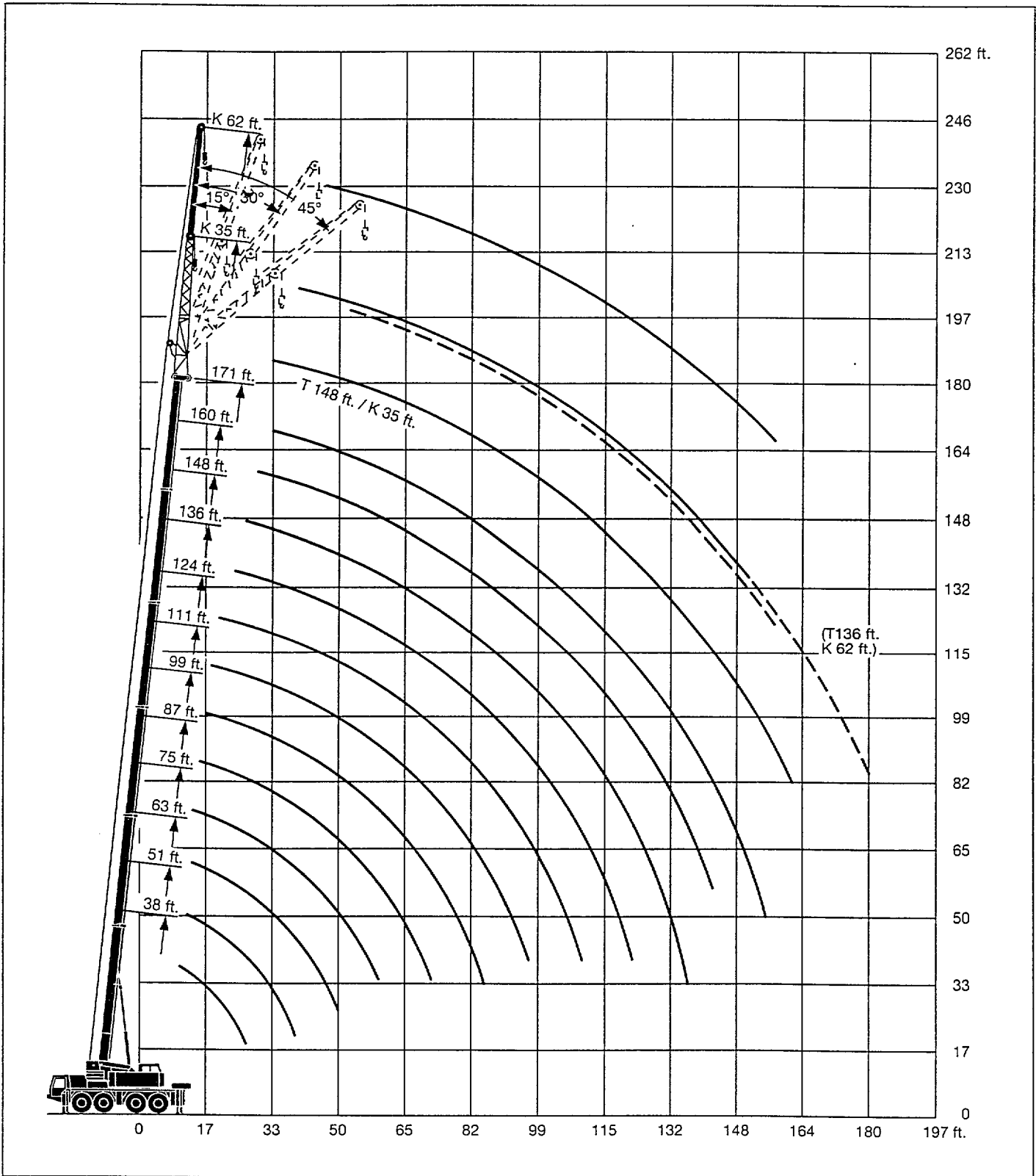



LTM 1090/2



38 ft - 63 ft



0°



44 100 / 31 800 lbs

85%

m	38 ft		51 ft		63 ft		m
	44 100 lbs	31 800 lbs	44 100 lbs	31 800 lbs	44 100 lbs	31 800 lbs	
10	53.7	51.8					10
11	50.2	48.4					11
12	47	45.3	48.8	47.1	48.4	47.9	12
13	44.1	42.5	45.9	44.3	46.5	45	13
14	41.5	40	43.3	41.8	44.1	42.6	14
15	39.1	37.6	40.9	39.4	41.7	40.2	15
16	36.9	35.5	38.8	37.3	39.5	38.1	16
17	35	33.6	36.8	35.4	37.6	36.2	17
18	33.2	31.8	35	33.7	35.8	34.5	18
20	29.7	28.5	31.5	30.3	32.3	31.1	20
22	26.9	25.7	28.7	27.5	29.5	28.3	22
24	24.3	23.2	26.2	25.1	26.9	25.9	24
26	22	21	23.9	22.9	24.6	23.6	26
28			21.9	21	22.7	21.8	28
30			20.1	19.2	20.9	20	30
32			18.5	17.5	19.3	18.5	32
34			17.2	15.9	18	17	34
36			15.9	14.4	16.7	15.5	36
38			14.7	12.9	15.5	14	38
40					14.3	12.6	40
45					12	9.9	45
50					10.2	7.9	50
I	0		0		0		I
II	0		0		0		II
III	0		0		0		III
IV	0		0		0		IV
% V	0		48		92		% V

0° = over rear / sur arriere

TAB 107023 / 107024



Lifting capacities at the folding jib.

Forces de levage à la fléchette pliante.

LTM 1090/2



124 ft - 171 ft

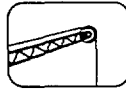

35 ft



360°



44 100 lbs

85%

m	124 ft				136 ft				148 ft				160 ft				171 ft			m		
	35 ft				35 ft				35 ft				35 ft				35 ft					
	0°	15°	30°	45°	0°	15°	30°	45°	0°	15°	30°	45°	0°	15°	30°	45°	0°	15°	30°			
28	24.3				20																28	
30	24.1				19.9																	30
32	23.9				19.8				17.2													32
34	23.6				19.7				17.1													34
36	23.4				19.6				17													36
38	23.1				19.5				16.9													38
40	23	17			19.2	14.7			16.6				13.6							11.8		40
45	23.9	15.8			13.7	13.7			16.6				13.1							11.3		45
50	22.4	14.7	10.2		19	12.8	8.6		16.3	10.9			12.7	8.4					10.7	7		50
55	21	13.8	9.7	7.6	18.7	12	8.3	6.4	15.7	10.4	7	5.4	12.2	8.1	6.1				10.2	6.7	4.8	55
60	20.2	12.9	9.3	7.4	18.2	11.3	7.9	6.2	14.8	9.8	6.8	5.2	11.7	7.8	5.9	4.4			9.7	6.5	4.6	60
65	18.6	12.1	8.9	7.2	16.9	10.6	7.6	6.1	13.9	9.2	6.5	5.1	11	7.5	5.7	4.3			9.1	6.2	4.4	65
70	16.7	11.5	8.6	7	15.6	10	7.3	5.9	13.1	8.7	6.3	5	10.3	7.3	5.5	4.2			8.7	6	4.2	70
75	14.8	10.8	8.2	6.8	14.5	9.5	7.1	5.8	12.4	8.3	6	4.8	9.8	7	5.3	4.1			8.3	5.8	4	75
80	13.2	10.3	7.9	6.7	13.3	9	6.8	5.7	11.7	7.9	5.8	4.7	9.3	6.8	5.1	3.9			7.9	5.6	3.8	80
85	11.7	9.7	7.6	6.5	11.9	8.5	6.6	5.6	11.2	7.5	5.6	4.6	8.8	6.6	4.9	3.8			7.5	5.4	3.7	85
90	10.2	9.3	7.4	6.4	10.5	8.1	6.4	5.5	10.3	7.2	5.4	4.5	8.4	6.4	4.7	3.7			7.2	5.2	3.5	90
95	9	8.9	7.2	6.3	9.3	7.8	6.2	5.4	9.3	6.8	5.3	4.4	8	6.1	4.6	3.6			6.8	4.9	3.3	95
100	8	8.3	7	6.2	8.3	7.4	6	5.3	8.3	6.5	5.1	4.3	7.7	5.8	4.4	3.5			6.6	4.7	3.2	100
105	7.1	7.6	6.8	6	7.4	7.1	5.9	5.3	7.4	6.3	5	4.3	7.4	5.6	4.3	3.5			6.3	4.5	3.1	105
110	6.7	6.7	6.6	5.9	6.9	6.8	5.8	5.2	7.1	6	4.8	4.2	6.7	5.4	4.2	3.4			6	4.2	2.9	110
115	6.4	5.9	6.1	5.8	6.7	6.2	5.6	5.1	6.8	5.8	4.7	4.1	6	5.2	4	3.3			5.6	4	2.8	115
120	6.2	5.4	5.5	5.4	6.4	5.5	5.4	5.1	6.3	5.4	4.6	4.1	5.3	5	3.9	3.3			5.1	3.8	2.7	120
125	5.9	5.2	4.8	4.8	6.2	5.4	5.1	5	5.6	5.1	4.5	4	4.7	4.8	3.8	3.2			4.4	3.6	2.6	125
130	5.7	5.1	4.7	4.3	5.7	5.2	4.7	4.5	5.1	4.9	4.4	4	4.1	4.4	3.7	3.2			3.9	3.5	2.5	130
135	5.5	5	4.6	4.2	5.2	5.1	4.6	4.2	4.5	4.7	4	3.8	3.6	3.9	3.6	3.1			3.4	3.3	2.4	135
140	5.3	4.8	4.5		4.8	4.8	4.5	4.1	4.1	4.3	3.9	3.6	3.1	3.4	3.4	3.1			2.9	3.1	2.3	140
145					4.3	4.5	4.4	4	3.6	3.9	3.8	3.5	2.7	3	3.2	3			2.4	2.8	2.2	145
150					3.9	4.1	4.1	3.9	3.2	3.4	3.5	3.5	2.3	2.5	2.7	2.8			2	2.3	2.1	150
155					3.5	3.6	3.6		2.8	3	3.1	3.1		2.1	2.3	2.4				1.9	2	155
160									2.4	2.6	2.6											160
I		92/0				92/0				92/46				92					100			I
II		92/46				92/92				92/92				92					100			II
III		92/92				92/92				92/92				92					100			III
IV		46/92				46/92				92/92				92					100			IV
V		0/92				46/92				46/92				92					100			V

TAB 107078 / 107080 / 107082 / 107084



LTM 1090/2



124 ft - 171 ft

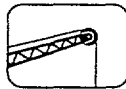

62 ft



360°



44 100 lbs

85%

m	124 ft				136 ft				148 ft				160 ft			171 ft		m	
	0°	15°	30°	45°	0°	15°	30°	45°	0°	15°	30°	45°	0°	15°	30°	0°	15°		
30	10.2																	30	
32	10.1																	32	
34	10.1				9.5													34	
36	10				9.4													36	
38	10				9.4													38	
40	9.9				9.3				8.2					7.3				40	
45	9.8				9.2				8.1					7.2				45	
50	9.6				9.1				8					7.1		6.1		50	
55	9.4	7.9			9	7.6			7.9					7		6		55	
60	9.2	7.8			8.8	7.5			7.8	6.8				6.8	5.5	6	4.3	60	
65	9	7.6			8.7	7.3			7.7	6.6				6.6	5.3	5.9	4.2	65	
70	8.8	7.5	6.3		8.5	7.2	5.6		7.6	6.4				6.6	5.1	5.8	4	70	
75	8.6	7.4	6.1	4.7	8.4	7.1	5.4		7.5	6.2	4.4			6.5	4.9	3.7	5.7	3.9	75
80	8.4	7.2	5.9	4.5	8.2	7	5.2	3.8	7.3	6	4.2	3		6.4	4.8	3.6	5.5	3.8	80
85	8.2	7.1	5.7	4.4	8	6.9	5	3.7	7.2	5.8	4	3		6.3	4.6	3.5	5.3	3.7	85
90	8	7	5.5	4.3	7.8	6.6	4.8	3.6	7.1	5.6	3.8	2.9		6.2	4.4	3.3	5.1	3.5	90
95	7.8	6.9	5.3	4.1	7.6	6.4	4.6	3.5	7	5.4	3.7	2.8	6	4.3	3.2	4.9	3.4		95
100	7.7	6.7	5.1	4	7.5	6.1	4.5	3.3	6.9	5.2	3.6	2.7	5.8	4.2	3	4.7	3.3		100
105	7.5	6.5	4.9	3.9	7.3	5.8	4.3	3.2	6.8	5	3.4	2.7	5.5	4.1	2.9	4.5	3.2		105
110	7.1	6.2	4.8	3.8	7.2	5.6	4.2	3	6.6	4.7	3.3	2.6	5.3	3.9	2.8	4.3	3.1		110
115	6.5	6	4.6	3.6	6.6	5.4	4	2.9	6.3	4.5	3.2	2.5	5.1	3.8	2.7	4.2	3		115
120	5.8	5.7	4.5	3.5	5.9	5.2	3.9	2.7	5.8	4.3	3.1	2.4	4.9	3.7	2.6	4	2.9		120
125	5.1	5.5	4.3	3.4	5.3	5	3.7	2.6	5.2	4.1	3	2.4	4.8	3.6	2.5	3.9	2.7		125
130	4.5	5.1	4.2	3.2	4.7	4.8	3.6	2.5	4.6	3.9	2.9	2.3	4.6	3.5	2.4	3.7	2.6		130
135	4.2	4.6	4.1	3.1	4.3	4.6	3.4	2.4	4.4	3.8	2.9	2.2	4.2	3.3	2.3	3.6	2.4		135
140	4	4.1	4	3	4.1	4.2	3.3	2.4	4.2	3.6	2.8	2.2	3.7	3.2	2.3	3.3	2.3		140
145	3.8	3.5	3.8	2.9	4	3.7	3.1	2.3	4.1	3.5	2.7	2.1	3.2	3	2.2	2.9	2.1		145
150	3.7	3.1	3.4	2.7	3.8	3.3	3	2.2	3.7	3.2	2.6	2	2.8	2.9	2.1	2.5	2		150
155	3.5	3	2.9	2.6	3.7	3	2.8	2.2	3.3	3	2.6	1.9	2.4	2.8	2	2.2	1.9		155
160	3.4	2.9	2.4	1.9	3.5	3	2.6	2.1	2.9	2.9	2.5	1.9	2	2.5	1.9				160
165	3.3	2.8	2.3		3.2	2.9	2.5	2.1	2.6	2.8	2.3			2.1	1.8				165
170	3.2	2.7	2.3		2.8	2.8	2.5	2	2.2	2.6	2			1.8	1.7				170
175	3.1				2.5	2.7	2.4		1.9	2.2	1.9								175
180					2.2	2.4					1.8								180
I	92/ 0				92/ 0				92/46				92			100		I	
II	92/46				92/92				92/92				92			100		II	
III	92/92				92/92				92/92				92			100		III	
IV	46/92				46/92				92/92				92			100		IV	
V	0/92				46/92				46/92				92			100		V	



Dimensions. Encombrement.

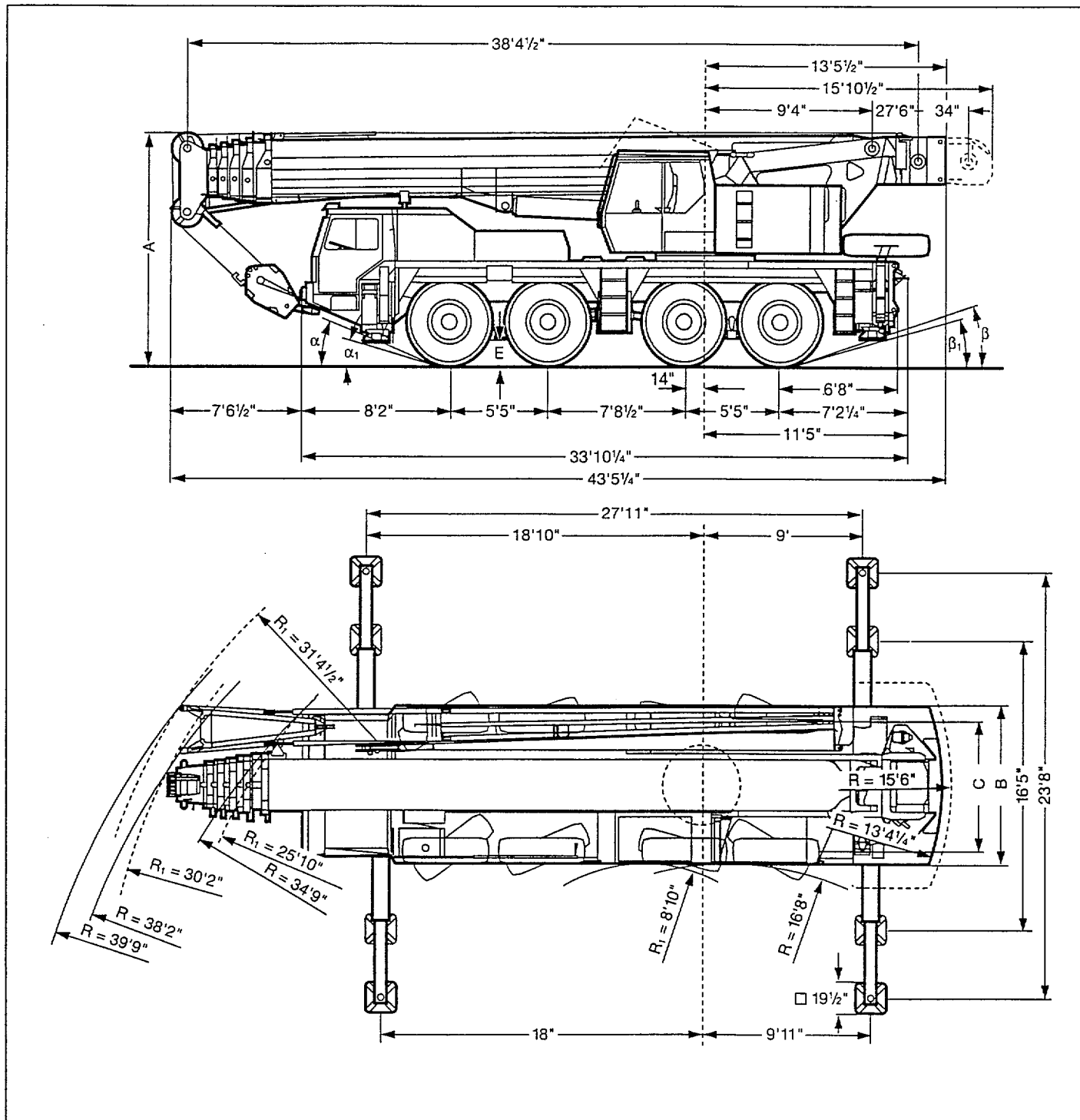

16.00 R 25	Dimensions / Encombrement									
	A	A 8''*	B	C	E	α	α_1	β	β_1	
	12'9 1/2"	12'5 1/4"	7'4"	8'9 1/4"	17"	22°	17°	18°	14°	

* lowered / abaissé



Weights. Poids.



Axle Essieu	1	2	3	4	Total weight Poids total
lbs	26455	26455	26455	26455	105820

with 2600 lbs counterweight and folding jib / avec contrepoids 2600 lbs et fléchette pliante

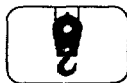

Load (kips) Forces de levage (kips)	No. of sheaves Poulies	No. of lines Brins	Weight lbs Poids lbs
198	7	14	2200
154	5	10	1760
110	3	7	990
48.5	1	3	730
16.5	-	1	420

Working speeds. Vitesses.

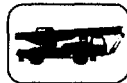

	1	2	3	4	5	R	
	5.9	14.8	23.4	34.2	47.8	10.3	42 %
	3.4	8.6	13.5	19.8	27.8	6	> 60 %
	16.00 R 25						



Drive Mécanismes	infinitely variable en continu	Rope diameter / Rope length Diamètre du câble / Longueur du câble	Max. single line pull Effort au brin maxi.
	0 - 390 ft/min single line ft/min au brin simple	²⁷ / ₃₂ " / 656'	17370 lbs
	0 - 390 ft/min single line ft/min au brin simple	²⁷ / ₃₂ " / 656'	17370 lbs
	0 - 2.0 rpm		
	approx. 50 seconds to reach 83.5° boom angle env. 50 s jusqu'à 83.5°		
	approx. 300 seconds for boom extension from 38 ft - 171 ft env. 300 s pour passer de 38 ft - 171 ft		



Crane carrier.

Frame:	Liebherr designed and manufactured, box type, torsion resistant, all-welded construction made of high-tensile structural steel.
Outriggers:	4-point support, all-hydraulic horizontal and vertical operation.
Engine:	6 cylinder, watercooled Liebherr Diesel, type D 9406 TI, 300 kW (408 HP) at 2100 rpm acc. to EEC standard (EURO 2), max. torque 1250 lbs-ft at 1500 rpm. Fuel tank capacity: 106 gallons.
Transmission:	Allison automatic transmission with torque converter and hydrodynamic retarder brake, 5 forward and 1 reverse speed. Transfer case with off-road range.
Axles:	All axles steered. Axles 1, 3 and 4 with planetary gears and differential locks.
Suspension:	All axles with hydropneumatic suspension and hydraulic locking facility.
Tyres:	8 tyres. Tyre size: 16.00 R 25.
Steering:	Hydraulic power steering with dual circuit hydraulic system, mechanical/hydrostatic from lower cab. Stand-by steering pump. Steering acc. to EC directive 70/311/EEC.
Brakes:	Service brake: Dual circuit, servo-air brake, acting on all wheels. TELMA type eddy current brake (wear resisting retarder). Hand brake: by spring action on all wheels of axles 2, 3 and 4. Brakes acc. to EC directive 71/320/EEC.
Driver's cab:	Spacious all-steel cab on resilient mountings, safety glass windows and full range of instruments.
Electrical system:	24 V DC, 2 batteries, lighting according to countries' regulations.

Crane superstructure.

Frame:	Liebherr-made, torsion-resistant, welded construction made of high-tensile structural steel. Connection to truck chassis by triple roller slewing ring, designed for 360° continuous rotation.
Crane engine:	4 cylinder, watercooled Liebherr Diesel, type D 914 TI, 125 kW (170 HP) at 1800 rpm acc. to DIN, max. torque 523 lbs-ft at 1400 rpm. Fuel tank capacity: 79 gallons.
Crane drive:	Diesel-hydraulic, with 1 duplex axial-piston pump with automatic output control, 1 duplex gear-type pump, open regulated hydraulic circuits.
Crane control:	By 2 control levers (joy stick type).
Hoist gear:	Axial piston fixed displacement motor, hoist drum with integrated planetary gear and spring loaded static brake.
Luffing gear:	1 differential hydraulic ram with safety check valve.
Slewing gear:	Axial piston fixed displacement motor, planetary gear, spring loaded static brake.
Crane cab:	All-steel construction fully galvanized, safety glazing, heater, controls and instruments.
Safety devices:	LICCON safe load indicator, hoist limit switch, safety valves against rupture of pipe and hoses.
Telescopic boom:	1 base section and 5 telescopic sections, hydraulically extendable under load. All sections extendable independently. Boom length: 38 ft to 171 ft.
Electrical system:	24 V DC, 2 batteries.

Complementary equipment.

Folding jib:	35 ft to 62 ft long, for mounting on telescopic boom at 0°, 15°, 30° or 45°.
2nd hoist gear:	For two-hook operation, or with folding jib in case main hoist shall remain reeved.
Drive 8 x 8:	Axle 2 additionally driven.

Other items of equipment available on request.